

INTELLICON 2000 SERIES

Variable Primary Controller For HVAC Air Cooled Plant Automation

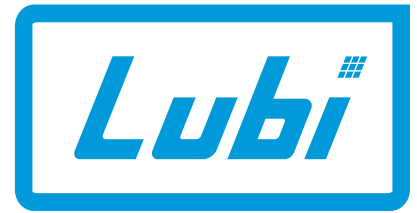

Passion for Pumps



INTRODUCTION

The Lubi **Intellicon 2000** is designed for automation of an air-cooled variable primary chiller plant. This controller lets you monitor and control up to five identical size air-cooled chillers and five variable primary pumps.

The variable speed technique offers a huge opportunity in energy savings and so is a must for Sustainable Green Energy Modern Buildings. Lubi Intellicon 2000 comes with built in Variable Speed Drive for each pump to controlled.

The Lubi Intellicon 2000 controller sequences the chillers and according to the demand of the zone it optimizes the pump operation in the most efficient way. The controller also adjusts the opening of the bypass valve to ensure minimum flow through the operating chillers.

Lubi Intellicon 2000 can be configured at site using user friendly set up screens on the color touch screen HMI. It can also be integrated to the Building Automation System (BAS) for remote monitoring and control.

APPLICATIONS

The Lubi Intellicon 2000 is suitable for variable primary chilled water plants for following:

- Commercial buildings
- Hotels
- Shopping complexes
- Hospitals
- Educational institutes
- Sports complexes
- Industries
- Airports

PRECONDITIONS FOR PROPER OPERATION

Intellicon 2000 will operate properly only if the below mentioned conditions are met.

- Chillers and pumps as well as Air Handling Units must be connected in parallel.
- Each chiller must have a differential pressure sensor connected across inlet and outlet.
- The pumping system must have a differential pressure sensor across inlet and outlet headers.
- A differential pressure sensor will be placed between inlet and outlet of each zone served by the plant.
- Electrically actuated chiller isolating valves are required for each chiller in the system.
- An electrically actuated bypass valve must be provided between the outgoing flow to the zones and incoming flow to the pumping system and chillers.

INTELLICON 2000 CONTROLLER CAPABILITY MATRIX

CONTROLLER TYPE	NOS. OF CHILLER UNITS	NOS. OF PUMPS	NOS. OF ZONES
Intellicon 2002	Up to 2	2 max.	3
Intellicon 2003	Up to 3	Up to 3	4
Intellicon 2004	Up to 4	Up to 4	5
Intellicon 2005	Up to 5	Up to 5	6

SYSTEM CONFIGURATION

● PUMPS

The following Lubi pumps are compatible with Intellicon 2000 controller.

- Vertical in-line pumps - LVI & LVS series
- End-suction pumps - LBS & LES series
- Horizontal split case pumps - LHC series.

● BYPASS VALVE

Automated bypass valves with a control signal of 4-20 mA are required. An input is also required to the controller for feedback of bypass valve position. Optionally on request, the controller can be modified to work with bypass valve with a control signal of 0-10V.

● SENSORS

SENSORS FOR CHILLERS, PUMPS & AIR HANDLING ZONES:

For chillers, pumps and air handling zones the controller requires differential pressure sensor with a signal of 4-20 mA.

FLOW SENSORS:

Magnetic flow meter is required with accuracy within 0.5% of actual reading at the calibrated velocity. The flowmeter shall provide an analog output of 4-20 mA linear to within $\pm 0.1\%$ of calibrated span.

TEMPERATURE SENSORS:

RTD type temperature transmitter with analog output of 4-20 mA.

All electrically actuated isolating valves and bypass valve are available from us at extra cost.

Differential pressure sensors, temperature sensors and flow sensors are also available from us at extra cost and are not including in price of Intellicon 2000.

ENCLOSURE

The enclosure is a key lockable IP54 rated cabinet. IP55 or NEMA 12 or NEMA 4 rated cabinets are available on request at additional cost.

OPERATOR INTERFACE

The Intellicon 2000 series controller is provided with a 4.3", 65336 color touch-screen HMI for all necessary user interface like set up, status monitoring, and alarms. Larger HMI up to 10.4" are available at an extra cost. A virtual Manual-Off-Auto switch is accessible through this display. In manual mode pump speed can be manually changed. The controllers are programmed to perform Online Self Diagnostic Tests of CPU, RAM and flash memory. Data stored within the controller will be protected during power supply interruptions.

Two level password security is standard on the Intellicon 2000 series controllers. Level 1 will enable the user to change the field adjustable parameter. Level 2 password will allow the factory Commissioning or Service Personnel to additionally adjust parameters which are factory set and generally are not required to be adjusted in the field.

INTEGRATION WITH BAS

Intellicon 2000 can be seamlessly integrated with any Building Automation System for Monitoring and Control using the following serial communication protocols. This feature is optional and can be requested at extra cost:

- ModBus RTU
- BACnet™ MS/TP or IP
- BACnet Ethernet
- LonWorks®

OPERATION LOGIC

All equipment connected to the Controller can be set in Manual-Off- Auto mode. If any equipment is set in Manual or OFF mode then it will not be automatically sequenced by the controller. Any Chiller or Pump, set in manual mode will start as soon as controller is kept on Manual mode. Any Chiller Isolation Valve kept in Manual mode can either be kept in Open or Close condition.

Following is the sequence of operation when the Controller is set in Auto mode.

- If the Controller is powered "ON" and is in "Enable" state the "Lead" Chiller will begin its start-up sequence which will in turn start handling the required pump and isolation valves.
- The Controller adjusts the pump operation using variable speed to maintain differential pressure across the Chiller within permissible range.

cont....

OPERATION LOGIC (CONT...)

- The controller then adjusts the pump operation further in order to meet the demand of Air Handling Zone with the highest differential pressure.
- If the flow rate is lower than the minimum flow rate required through the Chillers, the controller opens the bypass valve and thus maintains the minimum flow rate across the chillers.
- The cooling load of Air Handling Zones determines the number of chillers in operation.
- The controller stages "ON" the lag chillers based on the cooling load, high supply temperature, high flow, or power. Once a chiller is staged "ON" it will run for a minimum run time set in the controller.
- Before a chiller is staged "ON", in order to prevent freezing the running chillers, their capacity is reduced via their demand limit input or by reducing the primary flow.
- The pumping system performance is adjusted for the required flow by using variable speed control as well as cascade control which would cut in or cut out the pumps as required for optimized energy efficient operation. All pumps in operation will run at same speed.
- After a chiller is staged "OFF" it is kept out of sequencing for a period of time which is set in the controller.
- After a chiller is staged "ON" or "OFF" no more chillers are staged until a time period which is set in the controller.
- The controller maintains the flow between minimum and maximum flow required by the chiller at all times.
- Once all chillers are stopped, one pump continues to run to circulate water. The pump speed is determined to maintain differential pressure or temperature in the Air Handling Zones.
- If the supply temperature climbs above a threshold from set temperature in the controller then chillers starting with lead chiller are staged "ON" as required.
- Lead pumps as well as lead chillers are rotated periodically to balance their run hours.

ALARMS & ALARM HISTORY

Following alarms are generated and displayed on the HMI screen:

- System fault alarms
- General alarms
- Chiller alarms
- Pump alarms
- No flow alarms
- VFD fault alarms

A buzzer is provided in the controller to audibly alert the attention to an alarm on the HMI screen.

Alarm history is stored in the controller for future reference and download.

TYPICAL LAYOUT OF AIR COOLED VARIABLE PRIMARY CHILLED WATER PLANT

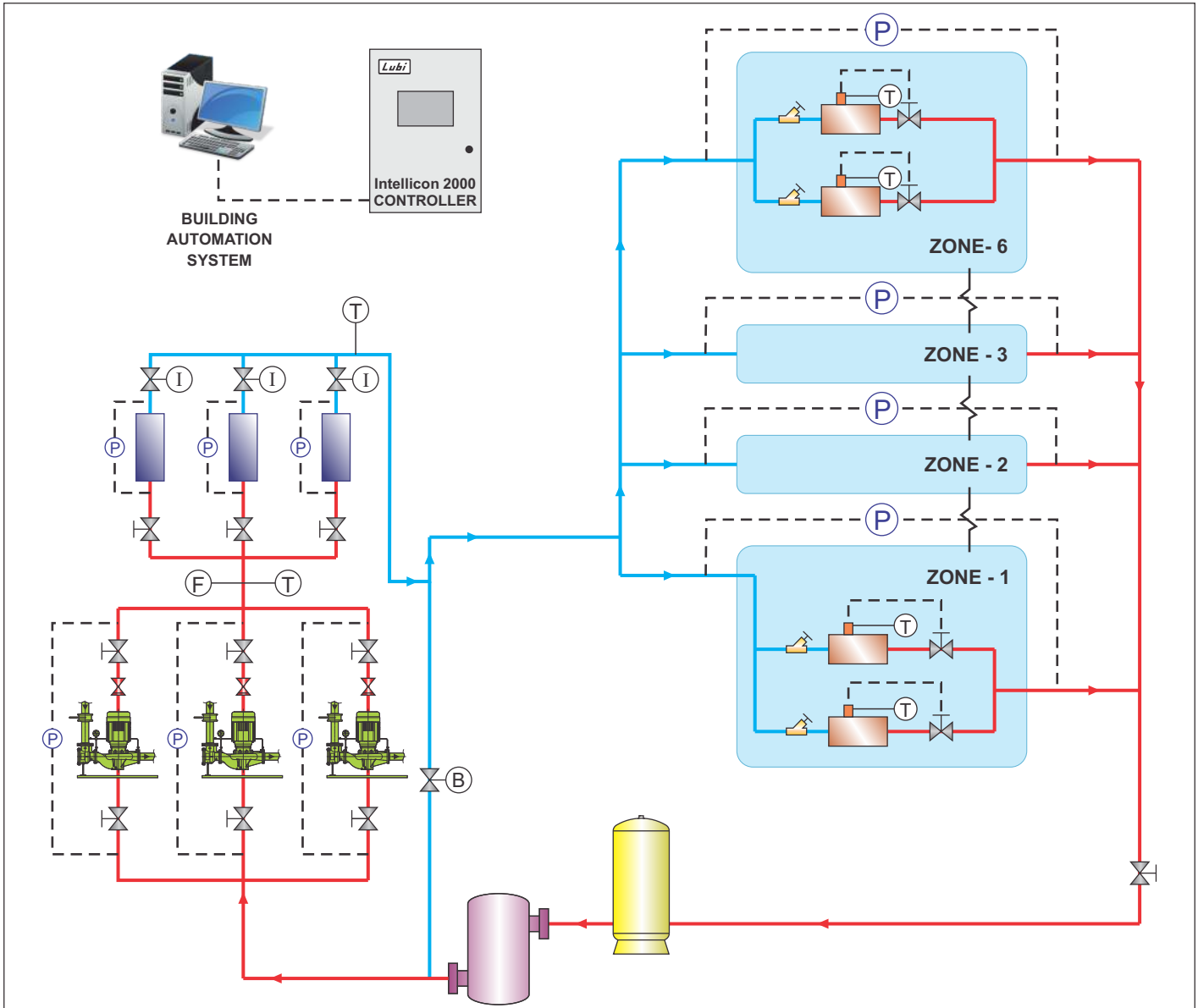

LEGEND KEYS

	PRIMARY PUMPS		TEMPERATURE SENSOR
	BALANCING VALVE		FLOW SENSOR
	2 WAY VALVE		AIR HANDLING UNIT (LOAD)
	NON-RETURN VALVE		CHILLER
	MOTORISED BYPASS VALVE		EXPANSION TANK
	MOTORISED ISOLATING VALVE		AIR SEPARATOR
	DIFFERENTIAL PRESSURE SENSOR (DPT)		

LUBI ELECTRONICS

Sardar Patel Ring Road, Nr. Karai Gam Patia, Nana Chiloda, Ahmedabad, Dist. : Gandhinagar - 382 330, Gujarat, INDIA.

Phone : +91 - 79 - 39845300, Fax No. : +91 - 79 - 39845599.

Sales Enquiries: info@lubielelectronics.com

www.lubielelectronics.com

Product Improvement is a continuous process at 'LUBI'. The data given in this publication is therefore subject to revision.

01.00.270817.0126



ISO 9001



ISO 14001